



# MX1100TXP

Hi-Power Electronic Keypad Blender with Timer and 48 oz. BPA-Free Copolyester Container



\*Made in USA with US and foreign parts.

## ELECTRICAL

Voltage: 120V

Frequency: 60Hz

Watts: 1560W

Amps: 12.5A

Plug Type: NEMA 5-15P

Cord Length: 6 feet



## MAIN FEATURES

- Heavy-duty, high-performance 3 1/2 peak HP motor with 2 speed selections is the strongest in its class. It powers through the toughest ice and frozen fruit mixtures in seconds.
- Super-high, 30,000+ RPM motor speed for the smoothest consistencies.
- Easy-to-clean electronic keypad with HIGH, LOW, STOP, ON/OFF, and PULSE controls and 30-second countdown timer.
- The Raptor® 48 oz. stackable, BPA-free copolyester container.
  - Ultra-aggressive blade and jar design delivers smoother consistencies and faster results.
  - Unbreakable, dishwasher-safe construction.
- High-performance, high-impact stainless steel blade is user replaceable for easy servicing.
- User-replaceable, metal-on-metal, stainless steel coupling system for durability and reliability.
- Easily removable container cover with removable clear cap lets you add ingredients and reduce pressure during hot food blending.
- Optional sound enclosure easily retrofits to base for noise reduction.
- Recommended for 75+ cycles per day.
- Limited Three-Year Motor and Two-Year Parts & Labor Warranty.

## SALES FEATURES

Get smooth, consistent results every time with the Waring® MX1100TXP. This heavy-duty 3½ peak HP blender teams up with The Raptor® jar and blade assembly for maximum power and efficiency. It's ferocious enough for everything from smoothies and frozen drinks to thick spreads, desserts, dressings and all types of food preparation. Features an easy-to-clean electronic membrane keypad with HIGH, LOW, STOP and PULSE functions, and a 30-second electronic countdown timer. Blend 75+ cycles per day. Perfect for a busy bar, health facility, school or coffee shop.

Hi-Power Electronic Keypad Blender with Timer and 48 oz. BPA-Free Copolyester Container **MX1100TXP**



# Hi-Power Electronic Keypad Blender with Timer and 48 oz. BPA-Free Copolyester Container MX1100TXP

## PARTS & ACCESSORIES

- |  |  |  |  |
|--|--|--|--|
|  | <b>CAC90</b><br>64 oz. Stainless Steel Container   |  | <b>CAC95-12</b><br>64 oz. Green Copolyester Container                      |
|  | <b>CAC93X</b><br>48 oz. Copolyester Container  |  | <b>CAC95-28</b><br>64 oz. Orange Copolyester Container                     |
|  | <b>CAC93X-03</b><br>48 oz. Yellow Copolyester Container  |  | <b>CAC116</b><br>Blending Assembly Kit and Retainer Ring Kit               |
|  | <b>CAC93X-06</b><br>48 oz. Blue Copolyester Container  |  | <b>CAC119</b><br>Retainer Ring Wrench                                      |
|  | <b>CAC93X-10</b><br>48 oz. Purple Copolyester Container  |  | <b>CAC158</b><br>Blending Assembly Kit                                     |
|  | <b>CAC93X-12</b><br>48 oz. Green Copolyester Container   |  | <b>CAC159</b><br>Retainer Ring Kit   |
|  | <b>CAC93X-28</b><br>48 oz. Orange Copolyester Container  |  | <b>CAC182</b><br>Drive Coupling  |
|  | <b>CAC95</b><br>The Raptor® – Aggressive, All-Purpose, Stackable, 64 oz., BPA-Free Copolyester Container |  | <b>CAC183</b><br>Drive Coupling with Square Drive                          |
|  | <b>CAC95-03</b><br>64 oz. Yellow Copolyester Container   |  | <b>CAC161</b><br>Drive Coupling Removal Tool                               |
|  | <b>CAC95-06</b><br>64 oz. Blue Copolyester Container   |  | <b>CAC169</b><br>Spatula – Custom designed for use with MX Series Blenders |
|  | <b>CAC95-10</b><br>64 oz. Purple Copolyester Container   |  | <b>SE1500</b><br>Sound Enclosure   |

## DIMENSIONS

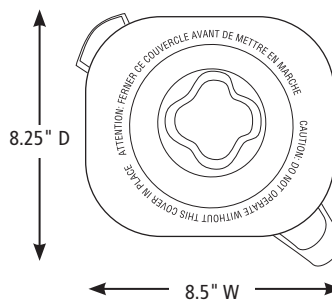
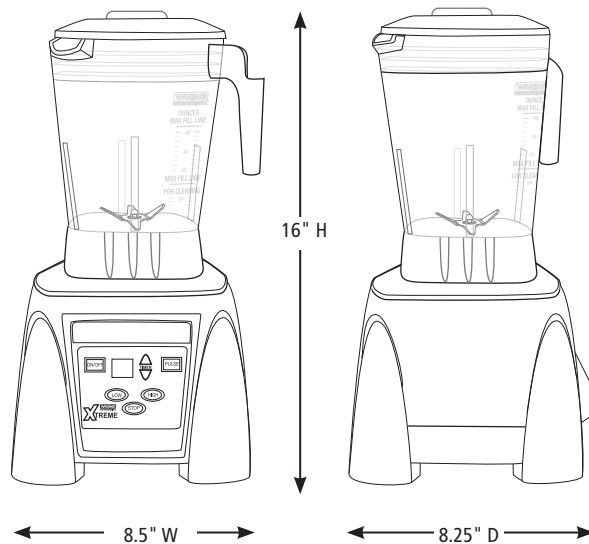

Out-of-Box Weight: 14.36 lb.

ORDERING INFORMATION	#STD. PKG.	GIFTBOX WEIGHT	CUBIC FEET	BOX DIMENSIONS D X W X H	UPC	CASE PKG.	MC WEIGHT	MC DIMENSIONS D X W X H	MBC
MX1100TXP– Hi-Power Electronic Keypad Blender with Timer and 48 oz. BPA-Free Copolyester Container	1	16 lb.	1.056	10.375" x 10.625" x 15.625"	040072031335	1	16 lb.	11.375" x 11.25" x 16.00"	10040072031332



# WolfLabs

**Pricing on any accessories shown can be found by keying the part number into the search box on our website.**

The specifications listed in this brochure are subject to change by the manufacturer and therefore cannot be guaranteed to be correct. If there are aspects of the specification that must be guaranteed, please provide these to our sales team so that details can be confirmed.

**[www.wolflabs.co.uk](http://www.wolflabs.co.uk)**

**Tel : 01759 301142**

**Fax : 01759 301143**

**[sales@wolflabs.co.uk](mailto:sales@wolflabs.co.uk)**

Please contact us if this literature doesn't answer all your questions.